

# Minimizing End-to-End Delay in Global HAHA Networks Considering Aeronautical Scenarios

Serkan Ayaz  
German Aerospace Center  
Institute of Communications  
and Navigation  
Muenchner Strasse 20  
82234 Wessling, Germany  
serkan.ayaz@dlr.de

Christian Bauer  
German Aerospace Center  
Institute of Communications  
and Navigation  
Muenchner Strasse 20  
82234 Wessling, Germany  
christian.bauer@dlr.de

Fabrice Arnal  
Thales Alenia Space  
26, avenue Champollion  
BP 33787 31037 Toulouse  
Cedex 1, France  
fabrice.arnal@thalesaleniaspace.com

## ABSTRACT

The International Civil Aviation Organization (ICAO) has recently standardized the IP-based aeronautical telecommunication network (ATN/IP) as a next generation communication network for the aviation industry. ATN/IP considers Mobile IPv6 (MIPv6) as a basic mobility protocol which only provides host mobility. However, considering large number of hosts within an aircraft, there is a need for network mobility (NEMO). IETF has already specified a NEMO protocol that introduces a new entity called Mobile Router (MR) in order to perform mobility signalling for all Mobile Network Nodes (MNNs) connected to the MR. However, the base NEMO protocol does not support route optimization (RO), a feature which provides better end-to-end delay performance. Up to now, different RO methods are proposed for NEMO in IETF and in this paper, we consider Global Home Agent to Home Agent (Global HAHA) as a NEMO RO solution in aeronautical environment and propose a new home agent selection method in order to minimize end-to-end delay in this network.

## Categories and Subject Descriptors

C.2.1 [Computer - Communication Networks]: Network Architecture and Design—*Wireless Communication*

## General Terms

Design

## Keywords

Mobile IPv6, Network Mobility, Route Optimization, Aviation

## 1. INTRODUCTION

The International Civil Aviation Organization (ICAO) has recently standardized the IP-based aeronautical telecommunication network (ATN/IP) [9]. In [9], Mobile IPv6 (MIPv6) [12] is considered as a basic mobility management protocol. Since MIPv6 supports only host mobility, there is a strong demand for network mobility (NEMO) in order to have a scalable mobility signalling if we consider an aircraft with multiple Mobile Network Nodes (MNNs) on board. The Internet Engineering Task Force (IETF) has already specified a NEMO protocol [5] that introduces a new network entity called Mobile Router (MR). The base NEMO specification however does not support route optimization (RO) feature, meaning that the packets exchanged between MNNs (on MR side) and Correspondent Nodes (on ground side) always traverse the Home Agent (HA).

In parallel to ICAO activities, Mobility Extensions for IPv6 (MEXT) Working Group (WG) under IETF has identified aviation use case for NEMO RO [11]. In this paper, we focussed on aviation scenario considering realistic ATN topology [4] and services defined in the air traffic management (ATM).

Until now, different NEMO RO methods are proposed and we will consider one of these solutions; namely Global Home Agent to Home Agent (Global HAHA) as a NEMO RO solution for aviation. The main idea behind Global HAHA approach is to distribute certain number of HAs within the network and let the MRs use any of them depending on the selection method. In Global HAHA network, one main problem is the HA selection in order to minimize the end-to-end delay. In [16], MR locates the topologically closest HA by using Dynamic Home Agent Address Discovery (DHAAD) mechanism, however other HA selection methods are also possible in order to minimize the end-to-end delay in such a network as we will discuss in this paper.

### 1.1 Service Types

In the ATN, there are two main service domains; namely Air Traffic Services (ATS) and Airline Operational Services (AOS) [6]. ATS Correspondent Nodes (CNs) are used to provide navigation, control and situational awareness services to the aircraft and AOS CNs are mainly used for business operations of airlines. One additional domain to ATS and AOS is the aeronautical passenger services (APS) domain. However, APC is not the focus of this paper since the ATN is not used for carrying this type of traffic.

Permission to make digital or hard copies of all or part of this work for personal or classroom use is granted without fee provided that copies are not made or distributed for profit or commercial advantage and that copies bear this notice and the full citation on the first page. To copy otherwise, to republish, to post on servers or to redistribute to lists, requires prior specific permission and/or a fee.

*MobiWac'09*, October 26–27, 2009, Tenerife, Canary Islands, Spain.  
Copyright 2009 ACM 978-1-60558-617-5/09/10 ...\$10.00.

## 1.2 Network Types

In the ATN, there are three main subnetworks [4] which will be explained in the following subsections.

### 1.2.1 ACSP

An Air/Ground Communications Service Provider (ACSP) operates an access network that includes air/ground data links. Global ACSPs (GACSP) have a world-wide network utilizing different terrestrial and satellite link technologies to provide ATS/AOS services. They are comparable to the tier 1 service providers in the Internet. In addition to GACSPs, there are local ACSPs (LACSP) which operate access networks in a limited area (e.g. airport domain). Since GACSPs have global network coverage, we assume GACSP network is an ideal candidate for the deployment of Global HAHA architecture in order to provide mobility services to the ATN users.

### 1.2.2 ANSP

An Air Navigation Service Provider (ANSP) manages the air traffic within a country or geographic region. Generally each ANSP has its own sub-network. An ANSP might also be an LACSP within that geographical region by operating its own air/ground access network, which might be due to security or cost motivations. ATS CNs are located within the ANSP subnetworks.

### 1.2.3 AO

Airline Operations (AO) network is used for managing the business operations of the aircraft that belong to a certain airline. Generally each AO has its own sub-network where AOS CNs are located.

## 2. BACKGROUND

### 2.1 Network Mobility (NEMO)

IETF standardized a network mobility (NEMO) protocol [5] in 2005. The protocol provides mobility support to the end nodes that are located in the mobile network accessed through the Mobile Route (MR). The MR extends mobile host functionality [12] in a way that it provides IP addresses to the connected end hosts from the assigned mobile network prefix (MNP). In parallel, the Home Agent (HA) provides a prefix table for the home registration of an MR which contains:

- MR Home Address (HoA) used as the key for searching the pre-configured prefix table.
- MNP associated with the MR HoA.

### 2.2 Dynamic Home Agent Address Discovery (DHAAD) Procedure

In [16], mobile nodes uses DHAAD [12] procedure in order to find the topologically closest HA. NEMO [5] extends the DHAAD (with a new flag (R) in request/reply message) so that the procedure is used by the MR. The procedure defines two types of Internet Control Message Protocol (ICMP) messages:

- ICMP HA address discovery request: MR sends DHAAD request message to the HAs anycast address. In our case, since we are using extended home network with /32 prefix, the anycast address should be constructed with /32 prefix instead of /64 home subnet prefix.

- ICMP HA address discovery reply: Topologically closest HA replies with its IP address (or a list of HA IP addresses operating in the Global HAHA network).

### 2.3 Home Agent Switch Message

RFC 5142 [8] provides a new mobility header message which is used for notifying the mobile node about a new home agent assignment. The message includes the list of possible HA addresses and MN selects one from the list. We are assuming that the list is ordered based on a certain selection criterion. One important consideration is that this message must be protected by IPsec Encapsulating Security Payload (ESP). After the MN receives the HA switch message, it should also re-establish the necessary SA with the new HA before sending the new Binding Update (BU).

### 2.4 Global HAHA Protocol

The base NEMO protocol [5] does not support route optimization, a feature which provides better end-to-end delay and network load<sup>1</sup> performance. Although research community proposed different NEMO RO solutions [14], none of them has been accepted as a standard by IETF until now. Considering the analysis of [3], we investigate further Global HAHA protocol [16] [20] as a NEMO RO solution in aeronautical environment and propose end-to-end delay optimizations in this network (i.e. the ATN). Figure 1 shows an example Global HAHA network architecture where each HA is connected to another via virtual private network (VPN) tunnels (i.e. HA-HA Tunnel) and announce their common /32 prefix (i.e. Extended Home Network [7]) via an Exterior Gateway Protocol (EGP) to the global Internetwork. According to [20], the home network prefix is a type of Provider-Independent (PI) prefix and announced by each HA to the global Internetwork. In addition, each Internet Service Provider (ISP) assigns another prefix to the corresponding home subnetwork (i.e. "locator prefix" [20]). In total, each home agent has two IP addresses: one from its ISP home subnet prefix and another from PI prefix.

In global HAHA network, each HA works either as a primary HA (pri\_HA) or as a proxy HA (pro\_HA) for an MR and each MR has a home address (HoA) configured either from the home network prefix or from its MNP depending on the deployment. From operational perspective, for example when a packet is sent from any CN to a MR whose primary HA is HA A, the packet is first routed to the topologically closest HA. In case the closest HA that intercepted the packet is not HA A, it tunnels the packet to HA A over HA-HA tunnel and HA A decapsulated the packet and then tunnels it to MR via MR-HA tunnel.

#### 2.4.1 Home Agent Types

The home agent (HA) with which the MR is currently registered is called primary HA. Each MR has only one primary HA. Other HAs are called proxy HA [20].

#### 2.4.2 Home Agent Binding Types

Reference [20] defines two different bindings: original and global binding. Original binding refers to a binding created by Primary HA in its local binding cache and global binding refers to a binding created by Proxy HAs based on the binding information sent by the primary HA. When a Proxy HA

<sup>1</sup>Network load term is used to show the total number of packets forwarded within the ground network

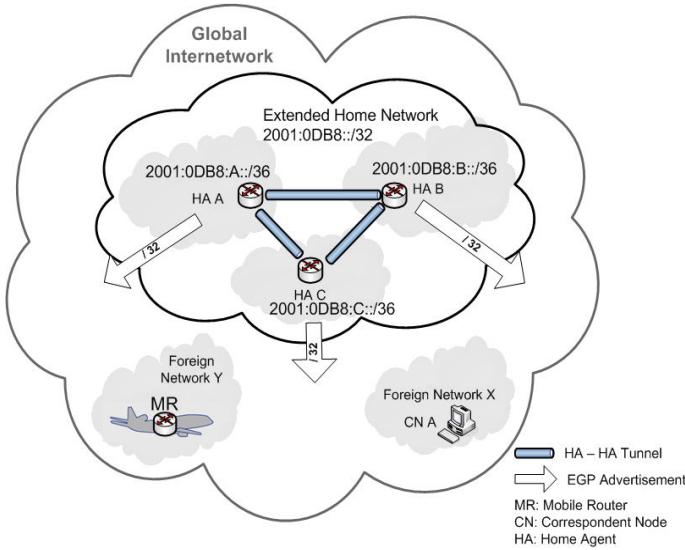

Figure 1: Global HAHA Network Architecture

receives a binding information update from Primary HA, it creates a route entry for the MR with the next hop showing the primary HA [20].

### 2.4.3 Inter-HAHA protocol

Global HAHA uses Inter-HAHA protocol for signalling between HAs [19]. It defines different message formats such as HELLO message, Binding Information Request/Update/Acknowledgement with new mobility options in order to carry the relevant information between HAs like MNPs and Binding Cache Entry information.

## 2.5 Multihoming

### 2.5.1 Multiple CoA Registration (MCoA)

MIPv6 allows registration of only one care-of address(CoA) as primary CoA in the binding cache of HA. However in case a mobile node simultaneously attaches to multiple access networks, it is able to configure multiple CoAs (i.e. MCoA) which could be used for different purposes (e.g. load balancing, make-before break handovers, etc.). The base specification of MCoA registration [18] defines a new identifier, called the Binding Identification (BID) number which is generated by the MR for each new CoA it wants to register to the HA with the Binding Update. Subsequently, the BID is an additional reference used for any operations related to this binding. The BID option to register multiple CoAs is supported through a new Binding Identifier Mobility option to be included in Binding Updates and Binding Acknowledgements.

### 2.5.2 Flow binding

The preliminary mechanism to bind flows with the available CoAs is to identify them. Two bytes Flow Identifier (FID) is suggested for this purpose in reference [15]. A flow can be identified by many ways (e.g. source/destination IP addresses, source/destination port numbers). In this paper, we use port numbers in order to identify ATS and AOS flows. Flow identification option (FIO) defined in [15] used with the HA binding registration process which is used to identify the

flows and to perform routing actions for them. FIO has a sub-option called Binding Reference Sub-option that carries BID information defined in the above subsection. Inside a flow binding list, each entry has certain parameters such as FID, Flow descriptor (e.g. TCP flow, UDP flow, port number, source IP address), BID, and priority information (FID-PRI).

## 3. HOME AGENT SELECTION METHODS

In this section, we will define two new HA selection mechanisms in order to minimize the end-to-end delay and network load.

### 3.1 Optimum HA selection in Global HAHA networks

As mentioned above, DHAAD is defined as one way of finding the topologically closest HA by the MR. However, it only considers the topological closeness of MR and HA which is not optimum if we consider end-to-end communication. End-to-end communication delay can be defined as<sup>2</sup>:

$$T_{OneWay-Total} = T_{MNN-MR} + T_{Wireless} + T_{AP-AR} + T_{AR-HA} + T_{HA-CN} \quad (1)$$

In eqn. 1:

- $T_{MNN-MR}$ : Mobile Network Node to Mobile Router Delay
- $T_{Wireless}$ : Mobile Router to Access Point Delay
- $T_{AP-AR}$ : Access Point to Access Router Delay
- $T_{AR-HA}$ : Access Router to Home Agent Delay
- $T_{HA-CN}$ : Home Agent to Correspondent Node Delay

As can be seen from the equation, the total delay considers the whole communication path (i.e. from MMN to CN via HA). For time critical applications like ATS and AOS, it is better to consider new HA selection methods that takes into account not only MR-HA communication path but also HA-CN communication path in order to minimize the end-to-end communication delay.

#### 3.1.1 Scenario

Considering Figure 2 where MR is attached to an access router (AR) in network B and communicating with a AOS CN in network C. In this case, it has the possibility of using one of two HAs in two different networks (assuming Global HAHA network).

In this scenario, two different end-to-end delay values via two different HAs can be computed as follows:

$$T_{Total-HA_A} = T_{MNN-MR} + T_{Wireless} + T_{AP-AR} + T_{AR-HA_A} + T_{HA_A-CN_{AOS}} \quad (2)$$

$$T_{Total-HA_C} = T_{MNN-MR} + T_{Wireless} + T_{AP-AR} + T_{AR-HA_C} + T_{HA_C-CN_{AOS}} \quad (3)$$

Let us assume that:

$$T_{AR-HA_A} < T_{AR-HA_C} \quad (4)$$

$$T_{Total-HA_A} > T_{Total-HA_C} \quad (5)$$

<sup>2</sup>Here the processing delays are neglected

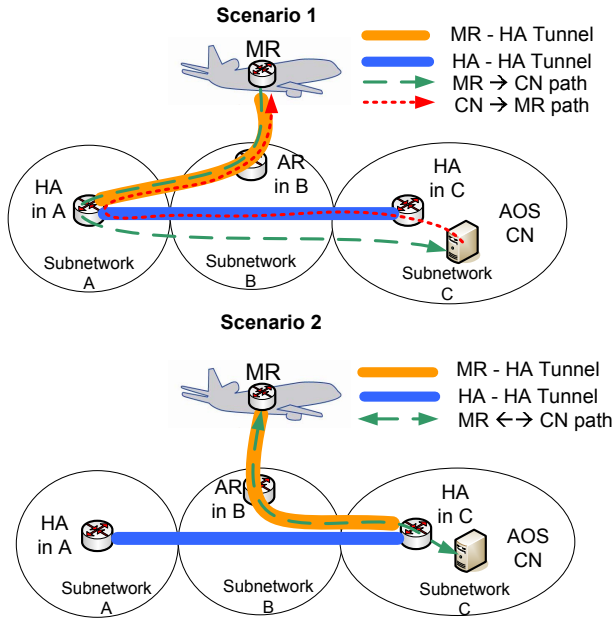

**Figure 2: Traffic Flows Between MR and Different HAs**

Under these conditions,  $HA_A$  will be used by the MR as an outcome of DHAAD procedure according to eqn. 4. However, in this case the total end-to-end delay is not minimized according to eqn.5.

### 3.1.2 Proposals

In this section, we will consider two different methods; namely static and dynamic, in order to select an HA that optimizes end-to-end delay. In static method, we are assuming that each HA has the knowledge of IP addresses of access routers (AR) and CNs in the network. Although this may not be a reasonable assumption for consumer electronics where each MR can connect to large number of CNs, we believe this could work in aviation scenario considering the limited number of access routers (AR) and CNs on the ground. In dynamic method, we do not make any assumption about the knowledge of ARs and CNs from HA side. HAs perform delay calculations when they receive a binding update with a new mobility option (i.e. Access Router Address Option).

#### Static Method.

In this method, each HA calculates the delay values to each access router (AR) and CN in the network (e.g. by using ping) and creates a delay table. After each HA completes the delay table, it exchanges this information with other HAs in the network. These exchanges are performed via special HELLO message defined in inter-HAHA protocol. There are two important points to mention at this stage;

- These tables are not very frequently updated since the ground network is quite stable and topology changes are rare.

- The networking entities (i.e. AR, HA, CN) are limited compared to public Internet so that the overhead generated due to delay calculation can be ignored at this stage.

Figure 3 shows a possible signalling exchange such that HAs first create delay tables and exchange those tables via

HELLO messages. Later on, MR attaches to a network and sends a DHAAD request. It is responded by the topologically closest HA (i.e. HA1) and MR performs binding registration with HA1. When HA1 receives the first user data from MR, it searches the optimum HA for the MR by checking the currently attached AR (here AR information is known by HA via the configured CoA) and the corresponding node address (which is the destination address in the inner header) from the delay table. If another HA provides a better delay performance, HA1 sends a HA switch request message [8] to the MR including the other HA address (e.g. HA2), and MR performs binding registration with that HA.

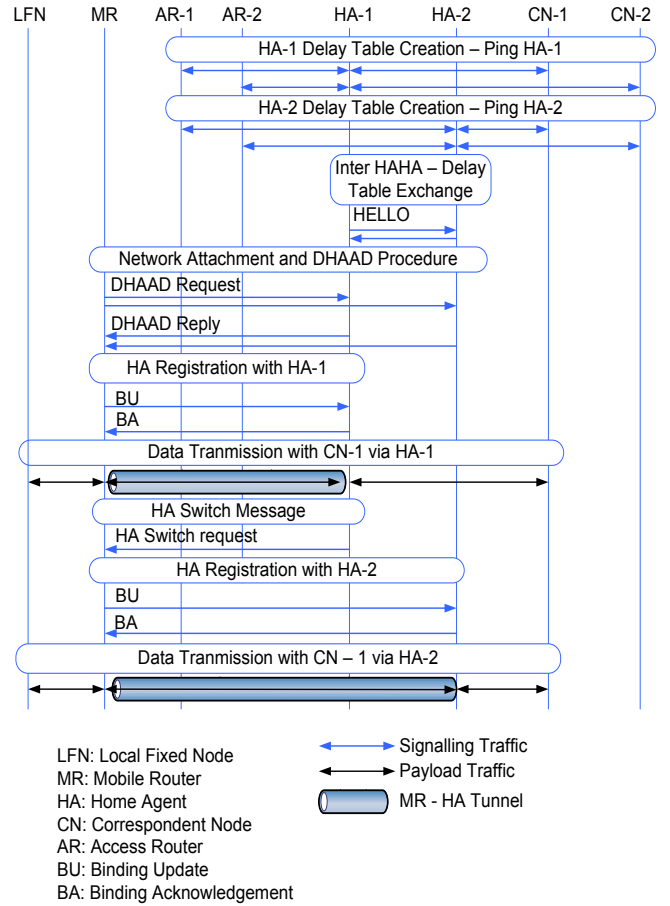

**Figure 3: DHAAD Procedure with HA Switch Message - Static Method**

#### Dynamic Method.

In this method, MR first learns the AR IP address and then informs HA about the address. MR uses two different methods for learning AR IP address. In the first case, it checks the source IP address in the received router advertisement message (i.e. during the network attachment) as shown in Figure 4. In the second method, if MR and access network is capable of using Information Server (IS) services of IEEE 802.21 [10], then MR learns about the attached AR IP address by using IS services. In this paper, we considered the first method since IEEE 802.21 can not be supported by all attached networks.

After MR learns about AR IP address, it inserts the AR IP address in the binding update (BU) with a new mobility option<sup>3</sup>. After HA receives the BU, it stores the AR IP address (with MR HoA, MR CoA and corresponding MNPs) and performs a ping to AR in order to measure delay. Later on, when it receives the first data packet from any MNN attached to the MR, it detunnels the packet and forward the traffic to the CN. In parallel since HA also learned CN address at that stage (i.e. CN address is the destination address of the inner header), it performs a ping to CN and measure the delay. Afterwards HA passes this information (i.e. AR and CN IP addresses with the corresponding delay values) to other HAs and they also measure these values and exchange with other HAs. These exchanges are also managed by HELLO messages similar to static method. After these exchanges are completed, the assigned HA checks from the table whether there is another HA which provides better performance. If the assigned HA finds a better one, it sends a HA switch message to MR which notifies the candidate HA address and MR performs binding registration with the new HA.

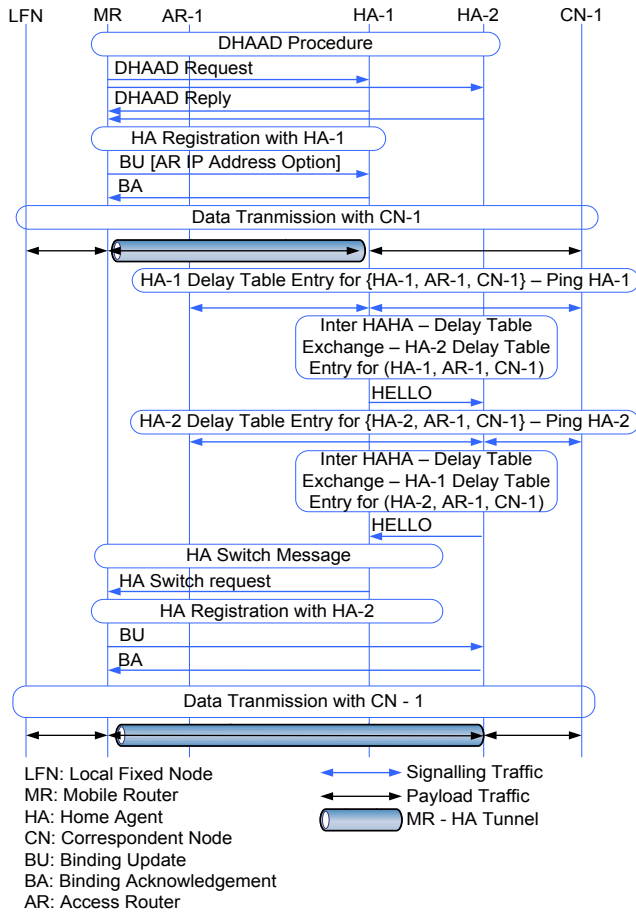

Figure 4: DHAAD Procedure with HA Switch Message - Dynamic Method

Although dynamic method does not require AR and CN IP address information beforehand for delay calculation, it is more penalizing with respect to handover delay performance

<sup>3</sup>Similar to the alternate Care-of Address Option

since it requires additional delay estimation phase for the new AR (assuming that the CN is not changed). However, in case HA has already the delay information (another MR that already used the corresponding AR and CN), then the delay estimation phase is not needed.

### 3.2 Example Comparison

In this section, we will show one example considering realistic backbone delay values (learned via ping application) between different regions of the world provided by [2]. In addition, we assumed a fixed 15 msec. delay value for AR-Backbone and HA-Backbone. As shown in Figure 5 aircraft is attaching to the network while flying around middle-east region and communicating with an corresponding node in Asia. In our configuration, we are assuming two HAs, one in Europe and one in Asia. In a regular situation, MR sends a DHAAD request and receives a reply from HA in Europe and starts using that HA. However, according to our proposal, the aircraft starts to use HA in Asia. Table 1 shows the corresponding end-to-end delay values.

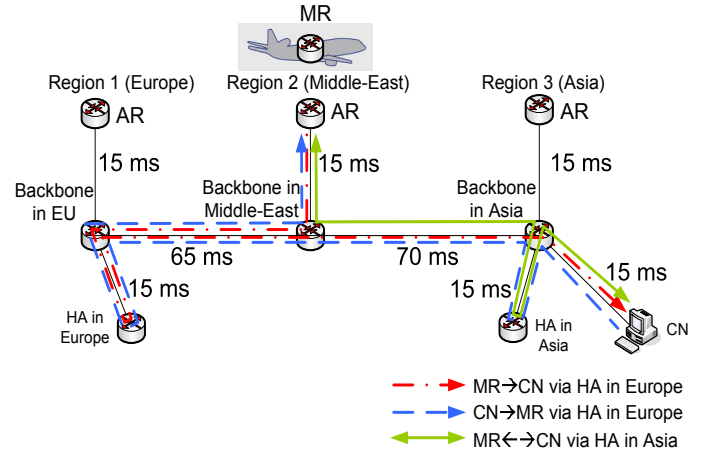

Figure 5: Example Scenario

Table 1: DHAAD vs. Proposed Solution Results

DHAAD Result	
Path	Delay <sup>4</sup> (msec.)
MNN->MR->CN	260
CN->MR->MNN	290
<b>Round Trip Time</b>	<b>550</b>
Proposed Solution Result	
Path	Delay <sup>4</sup> (msec.)
MNN->MR->CN	130
CN->MR->MNN	130
<b>Round Trip Time</b>	<b>260</b>

<sup>4</sup>The delay values are not considering the delay between MNN and the AR (i.e.  $T_{MNN-MR}$ ,  $T_{Wireless}$  and  $T_{AP-AR}$ ) since it is equal for both results.

### 3.3 Multiple HA usage in Global HAHA networks

In aeronautical communications, the aircraft is communicating with two different correspondent nodes in general; namely ATS and AOS. Based on the correspondent node type (be it ATS or AOS) the optimum HA is different considering the fact that there is not any direct relation between ATS CNs and AOS CNs. In this case, it is reasonable to consider multiple simultaneous bindings with different HAs within the Global HAHA network.

#### 3.3.1 Scenarios

Considering Figure 6, scenario 1 denotes a regular Global HAHA scenario where MR is allowed to register to only one HA. However in scenario 2, the MR is capable of registering simultaneously with multiple HAs in Global HAHA network, thanks to multihoming extensions. In scenario 2, the MR is notified by the above mentioned procedure about the optimum HAs for different flows. It is also good to mention that, since we are considering binding to multiple HAs, the HA switch message sent from the already registered HA carry not only candidate HA IP address but also FID, so that the MR knows for which flows the candidate HA will be used.

In this section we focus on scenario 2 and consider two different sub-scenarios which are aligned with two cases, namely (1,n,1) and (1,n,n) mentioned in [13]. The values inside parenthesis denotes number of MRs, number of HAs and number of MNPs respectively.

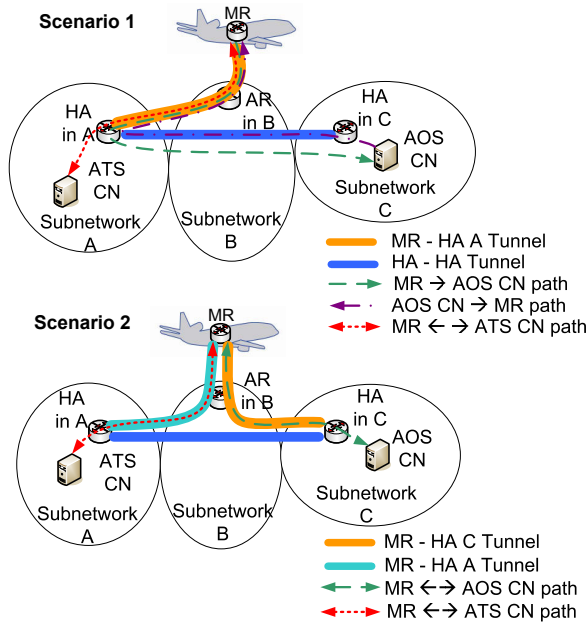

Figure 6: Traffic Flows with One and Multiple HAs

#### (1,n,n) Sub-scenario.

In this scenario ATS and AOS flows will have different MNPs and make use of different HAs inside Global HAHA network based on their optimality. Similar to basic NEMO protocol, MR uses only one Home Address (HoA) for ATS and AOS flows. Here we assume that the aircraft attaches to only one access network and configure only one CoA that is

used for each (HoA, CoA, MNP) 3-tuple. For each 3-tuple, MR performs binding registration to the optimum HA.

Similar to section 3.1.2, MR finds the topologically closest HA by using DHAAD procedure, sends two binding registrations for two MNPs<sup>5</sup> (i.e. (HoA, CoA, MNP1), (HoA, CoA, MNP2)) to the topologically closest HA. When MR sends the user data for each flow (here flow differentiation is based on MNP), HA checks whether it is the optimum HA, if not, then it sends a HA switch message to MR for the corresponding flow. Figure 7 shows an example binding registration setting where HA1 is optimum for ATS flows and HA2 is optimum for AOS flows. After MR sends the binding registration to HA1 and HA2, these HAs exchange binding information with each other by using Binding Information Update (BIU) message [19] in order to synchronize their binding caches for the corresponding MNP.

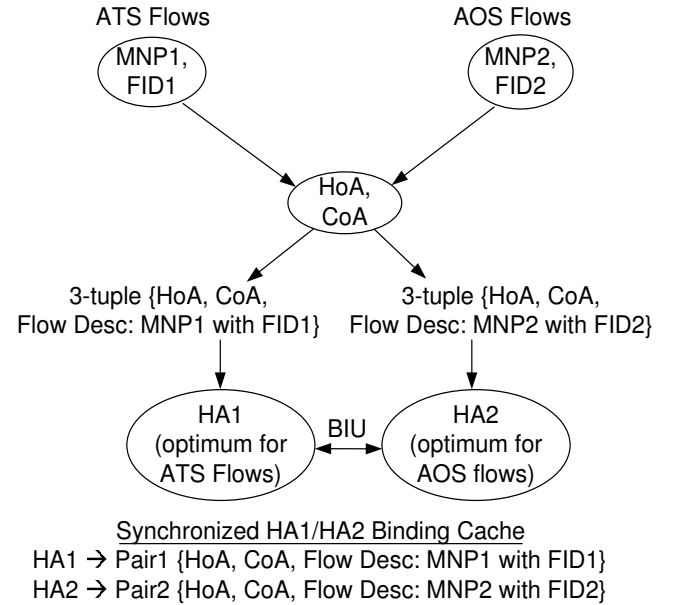

Figure 7: Binding Registration with Multiple MNPs

Another important issue might be to consider the case where another correspondent node (e.g. non-controlling ATS CN or another AOS CN) want to communicate with any corresponding MNP on board. In this case, when CN sends a packet to the mobile node, the packet will be intercepted by the closest HA which could be:

- Primary HA which has the current binding registration (HA in subnetwork A for ATS services): In this case primary HA will tunnel the packet directly to MR.

- Another HA which has received BIU from primary HA (HA in subnetwork B): In this case, there are two possibilities as mentioned in [19]. Either the HA sends the packet to the primary HA or sends it to the corresponding MR since it already knows the current CoA of MR via BIU. However in order to use the second option, MR should know in advance that the HA is a legitimate HA. This could be managed by statically configuring a legitimate HA list in MR. Otherwise, the first option should be used.

<sup>5</sup>One binding registration can also be used for registering multiple MNPs

### (1,n,1) Sub-scenario.

In this scenario, MR has two different (HoA, CoA, MNP, Port#) 4-tuple, and uses port numbers for flow identification (FID) [15] where each flow is differentiated with different bindings as shown in Figure 8. The procedures mentioned in the above section is also valid for this scenario.

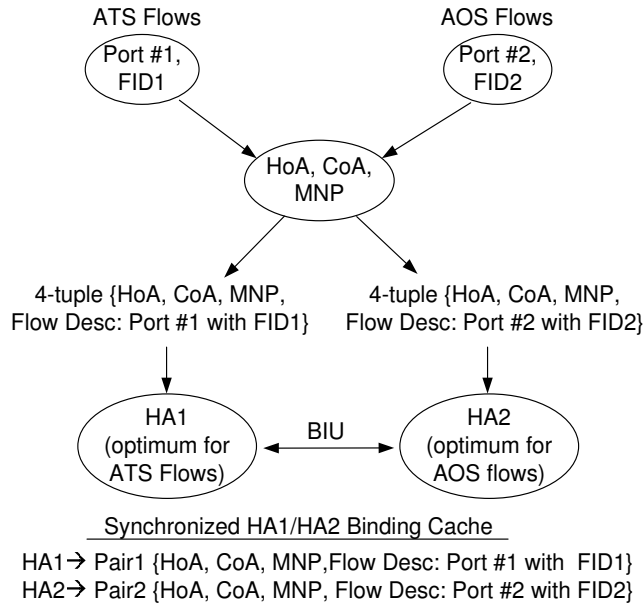

**Figure 8: Binding Registration Using Multiple Port Numbers as FID**

However, in this case since binding differentiation is based on port numbers, it is good to re-consider the packet forwarding from another CN (e.g. non-controlling ATS CN or another AOS CN) to MR. In this case, when the closest HA is:

- Primary HA: When it receives a packet from the CN, it checks the destination address and port number. If they are matching, HA will send it to the corresponding MR. In case port number is not matching, it is still possible to send the packet to MR since the received packet has valid destination address (i.e. any MNN address).

- Another HA: It has already received BIU (including port number and MNP information) from primary HA. When it receives a packet from the CN, it checks the destination address and port number. If it has a valid binding then the packet is tunneled either to the primary HA or to the MR considering the issues mentioned above in (1,n,n) sub-scenario.

## 4. CONCLUSIONS

In the first part of the paper, we presented a new HA selection method in order to minimize the end-to-end delay within the Global HANA network. The performance of the new procedure is basically based on the number of HAs deployed in the ground network. In case the network is populated with small number of topologically distributed HAs then the performance gain is more significant compared to large number of HAs. During the analysis, we have also realized that since ATS CNs are topologically close to the MRs, the outcome of the new selection method will be the

same as the outcome of DHAAD procedure since in this case the topologically closest HA also provides better end-to-end delay performance compared to other HAs. In the second part of the paper, we considered simultaneously binding with multiple HAs topic and provide information about how the binding caches of HAs look like in such a scenario. Since an aircraft is communicating with two topologically independent correspondent nodes (ATS and AOS CNs), it is good to make end-to-end delay calculations for each flow separately. Considering aeronautical environment where an aircraft communicates with limited number of correspondent nodes (i.e. ATS and AOS), these two optimization methods have certain applicability. As a next step, we will compare the performance of our approaches with DHAAD procedure through comprehensive simulations [17] and we will also analyze how IKE/IPsec security associations (SA) are affected when MR binds with multiple HAs simultaneously.

## 5. ACKNOWLEDGMENTS

This work is supported by the European Commission through the NEWSKY project [1] under contract no. 37160.

## 6. REFERENCES

- [1] NEWSKY Project Website. <http://www.newsky-fp6.eu>.
- [2] Sprint.net, Looking Glass. [https://www.sprint.net/lg/lg\\_start.php](https://www.sprint.net/lg/lg_start.php).
- [3] S. Ayaz, C. Bauer, W. M. Eddy, and F. Arnal. "NEMO Route Optimization Solution Space Analysis and Evaluation Criteria for Aviation". In *8th International Conference on ITS Telecommunications*, 2008.
- [4] C. Bauer and S. Ayaz. "ATN Topology Considerations for Aeronautical NEMO RO". draft-bauer-mext-aero-topology-00, IETF Draft, July 2008.
- [5] V. Devarapalli, R. Wakikawa, A. Petrescu, and P. Thubert. "Network Mobility (NEMO) Basic Support Protocol". RFC 3963, IETF, January 2005.
- [6] W. M. Eddy, W. Ivancic, and T. Davis. "NEMO Route Optimization Requirements for Operational Use in Aeronautics and Space Exploration Mobile Networks". draft-ietf-mext-aero-reqs-03, IETF Draft, January 2009.
- [7] T. Ernst and H.-Y. Lach. "Network Mobility Support Terminology". RFC 4885, IETF, July 2007.
- [8] B. Haley, V. Devarapalli, J. Kempf, and H. Deng. "Mobility Header Home Agent Switch Message". RFC 5142, IETF, January 2008.
- [9] ICAO. *Manual for the ATN using IPS Standards and Protocols (Doc 9896-AN 469)*. International Civil Aviation Organization, 2009.
- [10] IEEE. *Draft Standard for Local and Metropolitan Area Networks: Media Independent Handover Services (IEEE P802.21/D11.0)*. Institute of Electrical and Electronics Engineers, Inc., 2008.
- [11] IETF. "Mobility Extensions for IPv6 (MEXT) Working Group". <http://www.ietf.org/html.charters/mext-charter.html>.
- [12] D. B. Johnson, C. E. Perkins, and J. Arkko. "Mobility Support in IPv6". RFC 3775, IETF, June 2004.

- [13] C.-W. Ng, T. Ernst, E. K. Paik, and M. Bagnulo. "Multihoming in Network Mobility Support". RFC 4980, IETF, October 2007.
- [14] C.-W. Ng, F. Zhao, M. Watari, and P. Thubert. "Network Mobility Route Optimization Solution Space Analysis". RFC 4889, IETF, July 2007.
- [15] H. Soliman, G. Tsirtsis, N. Montavont, and K. Kuladinithi. "Flow Bindings in Mobile IPv6 and Nemo Basic Support". draft-ietf-mext-flow-binding-03, IETF Draft, July 2009.
- [16] P. Thubert, R. Wakikawa, and V. Devarapalli. "Global HA to HA Protocol". draft-thubert-mext-global-haha-00, IETF Draft, March 2008.
- [17] A. Varga. "The OMNeT++ Discrete Event Simulation System", 2005.
- [18] R. Wakikawa, V. Devarapalli, G. Tsirtsis, T. Ernst, and K. Nagami. "Multiple Care-of Addresses Registration". draft-ietf-monami6-multiplecoa-14, IETF Draft, May 2009.
- [19] R. Wakikawa, P. Thubert, and V. Devarapalli. "Inter Home Agents Protocol Specification". draft-wakikawa-mip6-nemo-haha-spec-01, IETF Draft, March 2006.
- [20] R. Wakikawa, Z. Zhu, and L. Zhang. "Global HA to HA Protocol Specification". draft-wakikawa-mext-global-haha-spec-01, IETF Draft, July 2009.